

PLAN

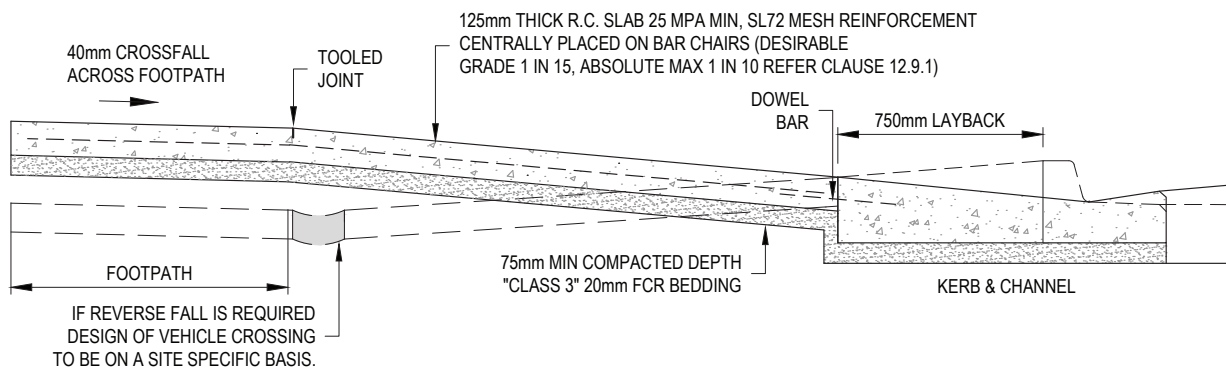



CROSS SECTION A-A

NOTES:

1. CROSS REFERENCES:
INDUSTRIAL CROSSINGS - SD250
RURAL CROSSINGS - SD255 / SD260
IDM - SECTION 12.9.1.
2. THIS DRAWING DETAILS DIMENSIONS FOR STANDARD RESIDENTIAL CROSSINGS ONLY.
3. CROSSING WIDTHS EXCEEDING THE MAXIMUM ALLOWABLE WILL REQUIRE APPLICATION FOR SPECIAL CONSIDERATION.
4. JOINTS AND DOWEL BARS ARE REQUIRED ON EITHER SIDE OF THE CROSSING AT THE INTERFACE WITH THE FOOTPATH. PROVISION SHALL BE MADE IN EXISTING CONCRETE SECTIONS BY DRILLING HOLES TO A MINIMUM DEPTH OF 150mm AND INSERTING R10 X 300mm LONG DOWEL BARS.
5. AN APPROVED JOINT FILLER SHALL BE PLACED ON EITHER SIDE OF THE CROSSING AGAINST FOOTPATH SLABS. DOWEL BARS ARE TO HAVE AN APPROVED BOND BREAKER APPLIED TO THE END OF THE BAR INSERTED INTO THE EXISTING CONCRETE FOOTPATH SECTIONS REFER SD220.
6. ADDITIONAL TOOLED JOINT REQUIRED IF DISTANCE FROM BACK OF KERB TO FOOTPATH IS GREATER THAN 3000 AND SHALL BE PLACED AT THE MIDPOINT OF THE DISTANCE.
7. THE MAXIMUM NUMBER OF CROSSINGS, WHERE ANY CROSSING EXCEEDS 3.5 METRES WIDTH, SHALL BE ONE (1) CROSSING WITH THE MAXIMUM WIDTH OF THAT CROSSING TO BE 6.0 METRES. CROSSINGS TO ADJACENT PROPERTIES SHALL BE EITHER FULLY COMBINED, AND OF MAXIMUM WIDTH OF 6.0 METRES, OR ELSE HAVE A MINIMUM SEPARATION OF 9 METRES.
8. FOOTPATHS OF 75mm THICKNESS ARE ACCEPTABLE ONLY WHERE THE LOTS ARE DEVELOPED ALREADY AND THE RISK OF SITE CONSTRUCTION DAMAGE IS NEGLIGIBLE. WHERE GREENFIELD SITES AND FUTURE HOUSING IS STILL TO BE DONE, THEN THE DEPTH OF THE FOOTPATH SHALL BE 125mm THROUGHOUT.

LEGEND:

- EXPANSION JOINT  E J
- TOOLED JOINTS  T J

ALL MEASUREMENTS IN MILLIMETRES

RETROFIT RESIDENTIAL VEHICLE CROSSING DETAIL

LAST UPDATED 29/03/2016

Infrastructure Design Manual Standard Drawings

A copy of the Infrastructure Design Manual can be viewed on the Design Manual website www.designmanual.com.au

SD 235

 Local Government Infrastructure Design Association

NOT TO SCALE